

Item	Part Number	Qty.	Description								
1	10002	2	HEX BOLT, 1/4-20 X 1 Gr.5 PLATED	50	10439	2	DUST CAP	99	25293	1	Yoke Weldment - Left Side
2	10021	2	HEX BOLT, 5/16" X 3" Gr.5 PLATED	51	10440	2	GREASE SEAL	100	25294	1	Yoke Weldment - Right Side
3	10032	16	HEX BOLT, 3/8 x 1-1/2 Gr.5 PLATED	52	10538	2	SLEEVE FOR 10419 PIN	101	25425	2	PIN WELDMENT, 5"
4	10035	2	HEX BOLT, 3/8" x 3" Gr.5 PLATED	53	10702	2	OUTRIGGER SHAFT	102	25435	1	PIN WELDMENT (4-1/2")
5	10072	6	HEX BOLT, 1/2 x 1 1/2 Gr.5 PLATED	54	11001	1	DECAL, DANGER - ROTATING BLADES	103	25476	1	CENTER GEARBOX SHIELD
6	10091	12	HEX BOLT, 5/8 X 1-1/2 Gr.5 PLATED	55	11002	2	DECAL, DANGER - KEEP CLEAR	104	25724	1	CYLINDER PIN WELDMENT
7	10092	5	HEX BOLT, 5/8" X 2" Gr.5 PLATED	56	11003	4	DECAL, CAUTION - SHIELD	105	26203	1	BLADE HOLDER W/BLADES COMPLETE (CCW)
8	10094	12	Hex Bolt, 5/8" x 3" Gr.5 PLATED	57	11004	1	DECAL, 8 POINT CAUTION	106	26204	1	BLADE HOLDER W/BLADES COMPLETE (CW)
9	10119	8	HEX BOLT, 3/4" X 6" Gr.5 PLATED	58	11005	1	DECAL, WARNING - THROWN OBJECTS	107	26205	1	DECK WELDMENT, 20126W
10	10121	4	HEX BOLT, 3/4" X 8" Gr.5 PLATED	59	11006	1	DECAL, SAFETY INSTRUCTIONS	108	26206	1	TAILWHEEL BAR WELDMENT
11	10127	2	Hex Bolt, 1 x 3 Gr.5 PLATED	60	11010	3	DECAL, LARGE HARDEE LOGO	109	26207	1	T-GEARBOX FRAME WELDMENT
12	10128	2	Hex Bolt 1" x 2-1/2" Gr.5 PLATED	61	11524	4	FLATWASHER, 1", USS, PLATED	110	26208	2	ROUND BLADE HOLDER WELDMENT
13	10134	2	HEX BOLT, 1" x 5-1/2" Gr.5 PLATED	62	11727	1	SERIAL NUMBER PLATE	111	26215	2	STRUT - 20126W
14	10150	10	LUG NUT (1/2" - 20 UNF)	63	11768	2	MAIN HUB, 6 SPLINE				
15	10154	4	LOCKNUT, 5/16"-18 PLATED	64	11769	6	RUBBER DISC, 6" DIA.				
16	10166	14	LOCKNUT, 5/8"-11 PLATED	65	11854	2	GEARBOX, RC-61, RATIO 1:1.93				
17	10168	28	LOCKNUT, 3/4"-10 Gr.5 PLATED	66	13488	4	GREASE FITTING, 1/8" NPT				
18	10171	6	HEX NUT, 1"-8 PLATED	67	15446	4	HEX BOLT, 3/4" X 8-1/2" Gr. 5 PLATED				
19	10173	2	CASTLE FLANGE NUT, 1"	68	15538	2	2200 SERIES NEAPCO CROSS KIT(U JOINT)				
20	10175	18	LOCKNUT, 3/8"-16 Gr.5 PLATED	69	15741	36	WASHER, SPACER				
21	10176	8	LOCKNUT, 1/2" (Gr.5 PLATED)	70	15852	2	RED REFLECTOR DECAL				
22	10179	2	CASTLE NUT, 3/4" Gr.5 Fine Thread	71	15853	2	YELLOW REFLECTOR DECAL				
23	10185	14	LOCKWASHER, 5/8" PLATED	72	15854	1	MANUAL HOLDER CANISTER				
24	10186	12	LOCK WASHER, 3/4" PLATED	73	15860	2	U-NUT, 1/4"-20 UNC				
25	10200	2	FLATWASHER, 1/4" PLATED	74	15875	1	Top Link Pin (QH Cat. 1, 2, & 3)				
26	10201	2	FLATWASHER, 5/16" PLATED	75	16539	2	HUB COMPLETE W/BEARINGS				
27	10202	32	FLATWASHER, 3/8" PLATED	76	16540	2	6"x 9", Laminated Tire, 5 on 5-1/2"				
28	10204	14	FLATWASHER, 1/2" USS PLATED	77	16840	4	DECAL, 5 YEAR GEARBOX WARRANTY				
29	10205	15	FLATWASHER, 5/8" PLATED	78	17019	1	DECAL, HARDEE MADE IN AMERICA LOGO				
30	10206	10	FLATWASHER, 3/4" PLATED	79	17053	2	DECAL, MODEL 20126W				
31	10207	2	FLATWASHER, 1" PLATED	80	20010	2	FORK COLLAR, TAILWHEEL				
32	10252	7	COTTER PIN, 3/16" X 2" PLATED	81	20031	2	ACCESS COVER				
33	10260	2	PLOW BOLT, 1/2" X 1-1/2" Gr.5 PLATED	82	21055	2	SHIELDING, 6-HOLES, FRONT				
34	10311	4	NUT, BLADE BOLT	83	21056	2	SHIELDING FLAT (FRONT)				
35	10312	4	LOCKWASHER, BLADE BOLT	84	21057	2	ANGLE, BELTING MOUNT				
36	10313	4	BLADE BOLT, 1-1/4"	85	25042	1	Slide Weldment - Right Hand				
37	10339	2	POP RIVET	86	25043	1	Slide Weldment - Left Hand				
38	10343	1	RATCHET JACK	87	25103	1	REPLACEABLE SLIDE, CENTER				
39	10346	3	LYNCH PIN W/SNAP RING, CAT. 1 & 2	88	25123	2	SHIELD, OUTRIGGER SHAFT, 20126W				
40	10378	1	DRIVESHAFT, SLIP CLUTCH	89	25175	4	SPRING SPACER WELDMENT				
41	10391	1	CLIP PIN (Hairpin) 3/16 X 3-1/4"	90	25194	4	COMPRESSION SPRING				
42	10415	1	T GEARBOX, RC-61	91	25199	2	BOTTOM FLAT				
43	10419	2	HITCH PIN, CAT. 2 & 3, CLEVIS STYLE	92	25212	2	ARM WELDMENT, TAILWHEEL				
44	10422	2	OUTRIGGER SHAFT	93	25213	2	Tailwheel Mounting Bracket Weldment				
45	10422	2	SHAFT FOR OUTRIGGER SHAFT	94	25264	1	A-FRAME WELDMENT, 20168W				
46	10424	2	BLADE, COUNTER-CLOCKWISE	95	25265	1	SKID MOUNTING WELDMENT				
47	10425	2	BLADE, CLOCKWISE	96	25278	2	PIVOT SPACER, A-FRAME				
48	10437	2	INNER BEARING	97	25281	1	SPACER, LOWER STRUT				
49	10438	2	OUTER BEARING - REPLACEMENT CUP-10441	98	25285	2	SHIELD BRACKET WELDMENT				

DWG. NO.	26200	REV.	IR
REV	CHANGE	BY	DATE
IR	INITIAL RELEASE	M.J.Z.	12/3/24
			1827

MODELED BY	M. J. Z.	2/18/23	<b>HARDEE BY EVH MFG. CO. LORIS S.C.</b>
CHECKED BY	C. K. N.	12/3/24	
MATERIAL	R.M.N.	N/A	DESCRIPTION SHEET 1 of 6
All Dimensions in Inches Unless Otherwise Specified Dimensions in [ ] are in Millimeters Tolerance Unless Otherwise Specified Fractional Dimensions: 1/16" Angular Dimensions: 1° Decimal Dim. to Limits Shown All Holes to be +0 -1/32"			20126W, 126" H.D. LIFT TYPE COMPLETE ASM.
Manufactured By: <b>EVH Mfg. Co., LLC</b>			DO NOT SCALE DWG. NO. 26200

DWG. NO.	26200	REV.	IR
REV	CHANGE	BY	DATE
IR	INITIAL RELEASE	M. J. Z.	12/3/24
			ECN
			1827

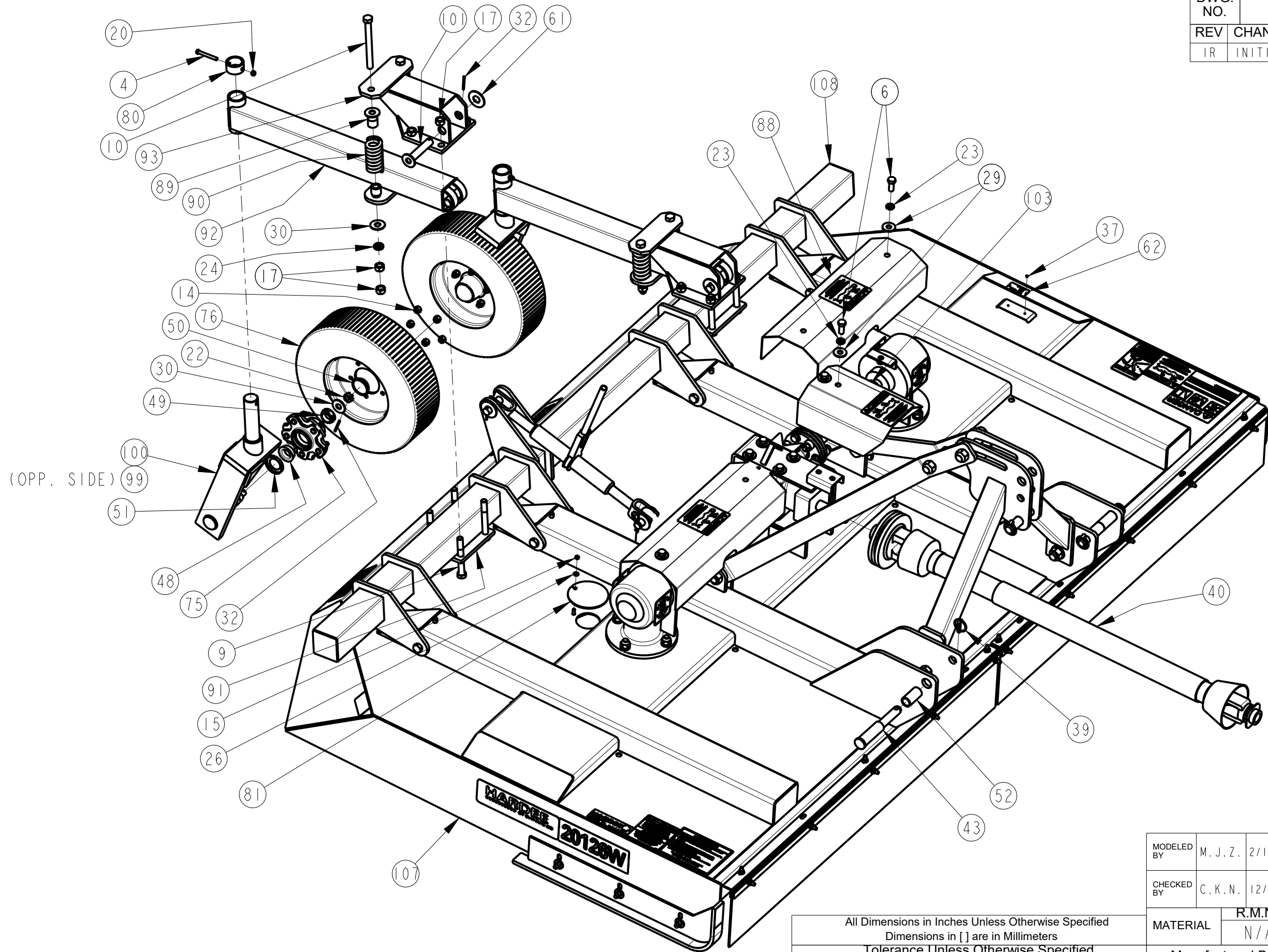

All Dimensions in Inches Unless Otherwise Specified  
 Dimensions in [ ] are in Millimeters  
 Tolerance Unless Otherwise Specified  
 Fractional Dimensions: 1/16" Angular Dimensions: 1°  
 Decimal Dim. to Limits Shown All Holes to be +0 -1/32"

MODELED BY	M. J. Z.	2/18/23	<b>HARDEE BY          EVH MFG. CO.          LORIS S.C.</b>
CHECKED BY	C. K. N.	12/3/24	
MATERIAL	R.M.N.	N/A	DESCRIPTION
Manufactured By: <b>EVH Mfg. Co., LLC</b>			SHEET 2 of 6 20126W, 126" H.D. LIFT TYPE COMPLETE ASM.
DO NOT SCALE	B	DWG. NO.	26200
	DWG. SIZE		

DWG. NO.	26200	REV.	IR	
REV	CHANGE	BY	DATE	ECN
IR	INITIAL RELEASE	M.J.Z.	12/3/24	1827

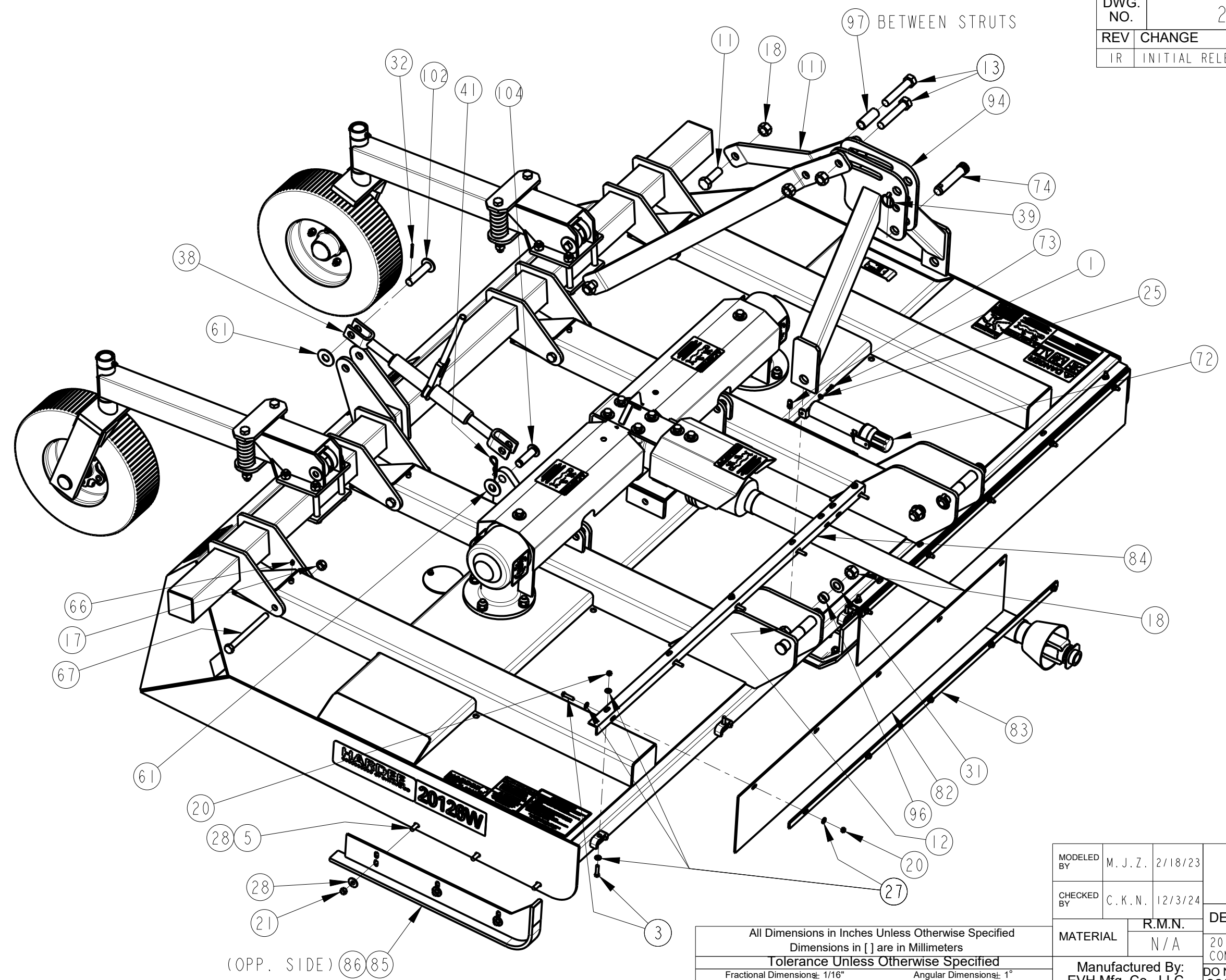

All Dimensions in Inches Unless Otherwise Specified  
 Dimensions in [ ] are in Millimeters  
 Tolerance Unless Otherwise Specified  
 Fractional Dimensions: 1/16" Angular Dimensions: 1°  
 Decimal Dim. to Limits Shown All Holes to be +0 -1/32"

MODELED BY	M. J. Z.	2/18/23	<b>HARDEE BY EVH MFG. CO. LORIS S.C.</b>	
CHECKED BY	C. K. N.	12/3/24		
MATERIAL	R.M.N.	N/A	DESCRIPTION	SHEET 3 of 6
Manufactured By: EVH Mfg. Co., LLC			20126W, 126" H.D. LIFT TYPE COMPLETE ASM.	
DO NOT SCALE	B	DWG. NO.	26200	

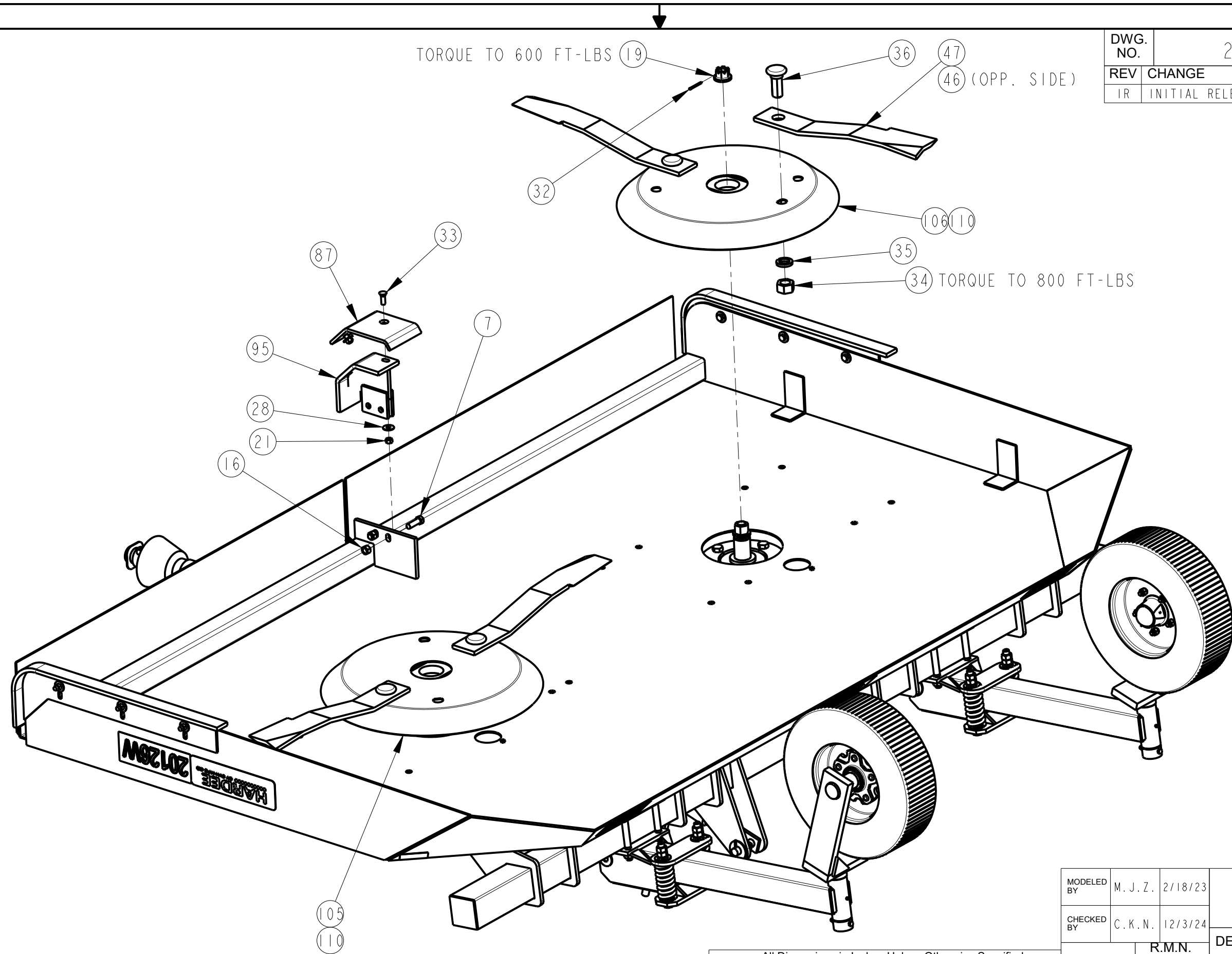

DWG. NO.	26200	REV.	IR	
REV	CHANGE	BY	DATE	ECN
IR	INITIAL RELEASE	M. J. Z.	12/3/24	1827

All Dimensions in Inches Unless Otherwise Specified  
 Dimensions in [ ] are in Millimeters  
 Tolerance Unless Otherwise Specified  
 Fractional Dimensions: 1/16" Angular Dimensions: 1°  
 Decimal Dim. to Limits Shown All Holes to be +0 -1/32"

MODELED BY	M. J. Z.	2/18/23	<b>HARDEE BY          EVH MFG. CO.          LORIS S.C.</b>	
CHECKED BY	C. K. N.	12/3/24		
MATERIAL	R.M.N.	N/A	DESCRIPTION	SHEET 4 of 6
Manufactured By: <b>EVH Mfg. Co., LLC</b>			20126W, 126" H.D. LIFT TYPE COMPLETE ASM.	
DO NOT SCALE	B	DWG. NO.	26200	
	DWG. SIZE			

DWG. NO.	26200	REV.	IR
REV	CHANGE	BY	DATE
IR	INITIAL RELEASE	M. J. Z.	12/3/24
			ECN
			1827

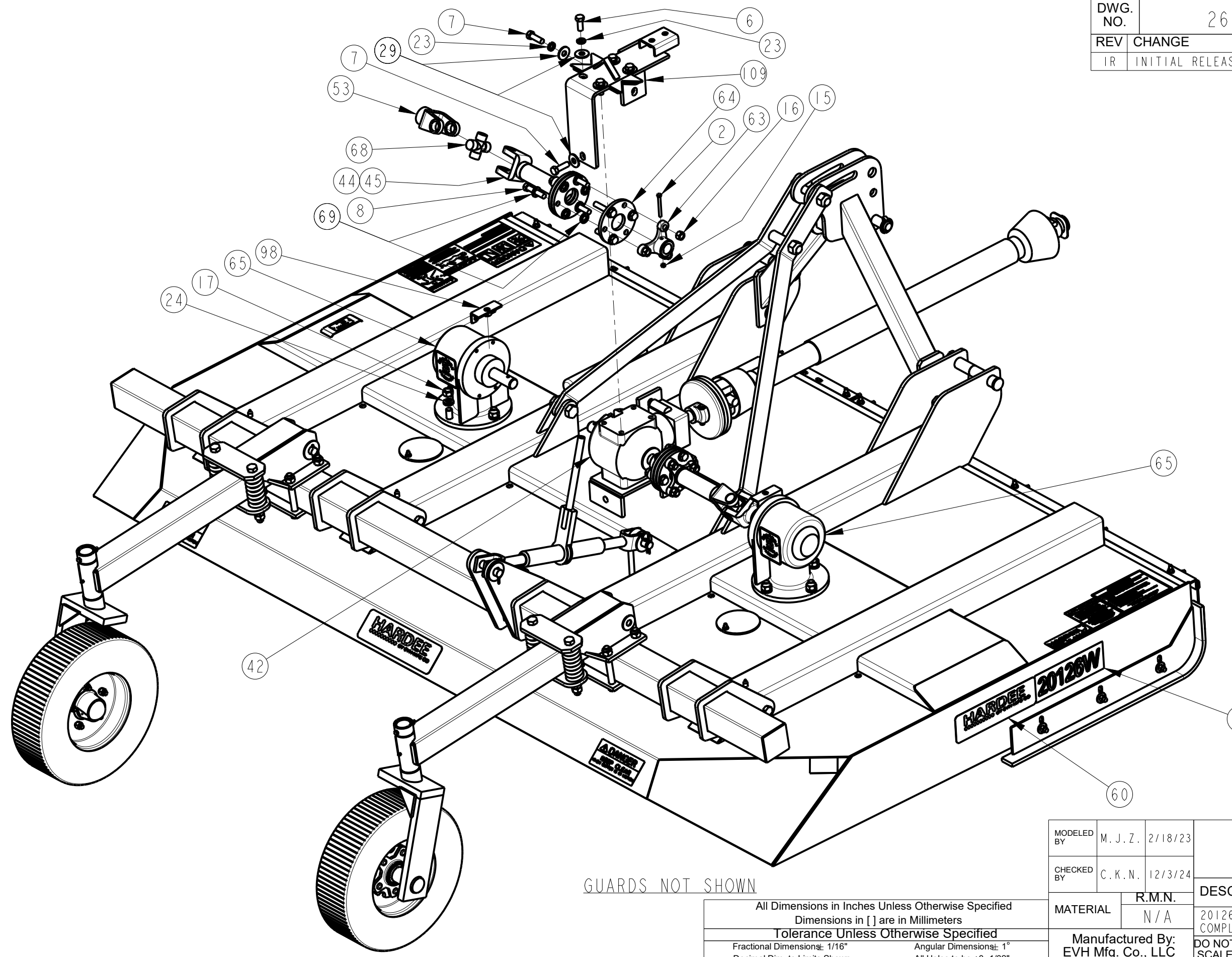

GUARDS NOT SHOWN

All Dimensions in Inches Unless Otherwise Specified  
 Dimensions in [ ] are in Millimeters  
 Tolerance Unless Otherwise Specified  
 Fractional Dimensions: 1/16" Angular Dimensions: 1°  
 Decimal Dim. to Limits Shown All Holes to be +0 -1/32"

MODELED BY	M. J. Z.	2/18/23
CHECKED BY	C. K. N.	12/3/24
MATERIAL	R.M.N.	N/A
Manufactured By: EVH Mfg. Co., LLC		

HARDEE BY EVH MFG. CO. LORIS S.C.	
DESCRIPTION	SHEET 5 of 6
20126W, 126" H.D. LIFT TYPE COMPLETE ASM.	
DO NOT SCALE	DWG. NO. 26200

DWG. NO.	26200	REV.	IR
REV	CHANGE	BY	DATE
IR	INITIAL RELEASE	M.J.Z.	12/3/24
			ECN
			1827

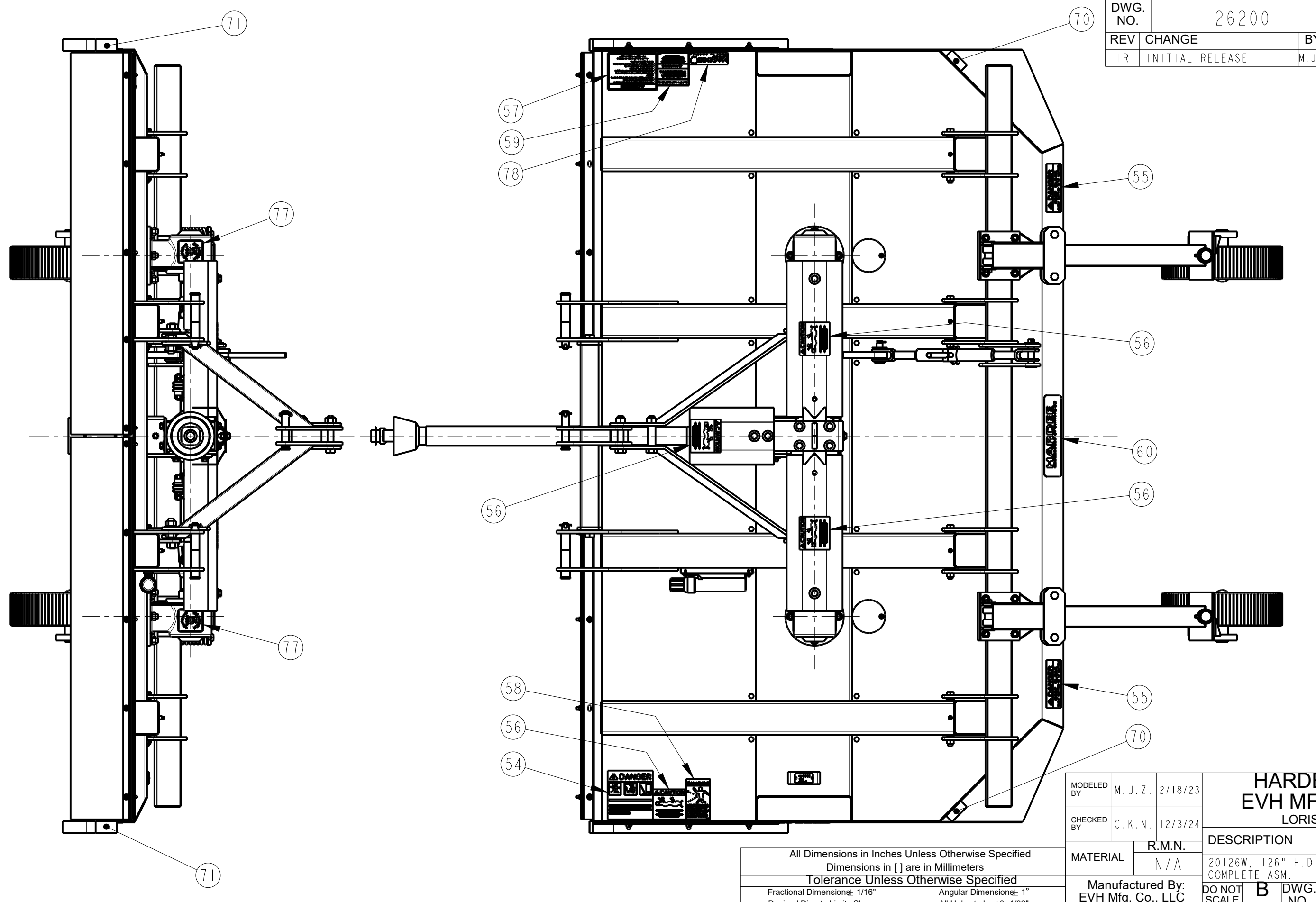

All Dimensions in Inches Unless Otherwise Specified  
 Dimensions in [ ] are in Millimeters  
 Tolerance Unless Otherwise Specified  
 Fractional Dimensions: 1/16" Angular Dimensions: 1°  
 Decimal Dim. to Limits Shown All Holes to be +0 -1/32"

MODELED BY	M. J. Z.	2/18/23
CHECKED BY	C. K. N.	12/3/24
MATERIAL	R.M.N.	N/A
Manufactured By: EVH Mfg. Co., LLC		

<b>HARDEE BY EVH MFG. CO. LORIS S.C.</b>	
DESCRIPTION	SHEET 6 of 6
20126W, 126" H.D. LIFT TYPE COMPLETE ASM.	
DO NOT SCALE	DWG. NO. 26200

# DRIVESHAFT 10378

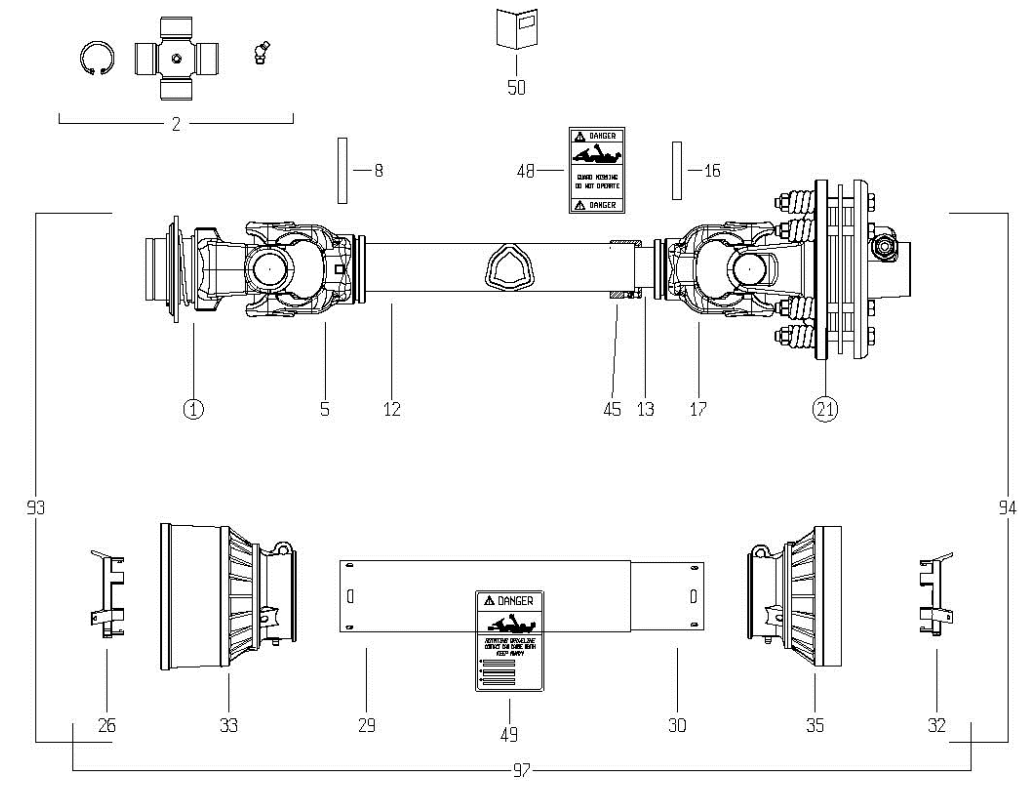

①

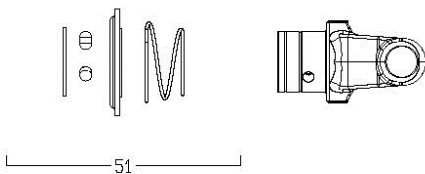

②①

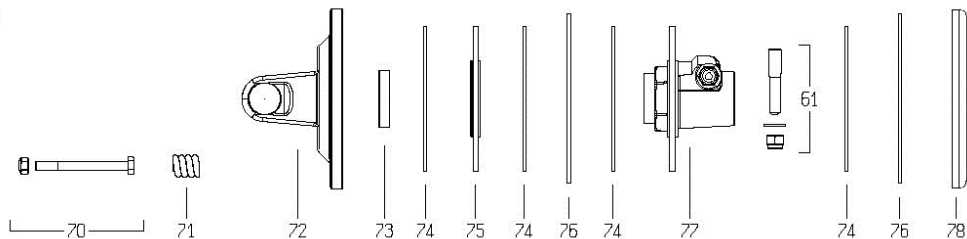

Key #	Part #	Description	Key #	Part #	Description
1	15571	Yoke – 1-3/8” Z6	70	15584	Cross Journal Assem.
2	15572	Cross Kit-Zerk in Body	71	15561	Coil Spring-Clutch
5	15573	Yoke-Outer Tube	72	16703	Flanged Yoke
8	98756	Flexible Roll Pin-Outer	73	16865	Bushing-Clutch
16	98160	Flexible Roll Pin-Inner	74	16864	Lining – Friction Disc
17	15577	Yoke-Inner Tube	75	16866	Lining Support
21	16870	Clutch – 1-3/8” Z 6	76	16704	Inner Plate
26	98142	Shield Support-Outer	77	16869	Flange Hub 1-3/8 Z6
32	98143	Shield Support-Inner	78	15799	Clutch Pressure Plate
51	16702	Ball Collar Kit	97	16868	Complete Shield Kit
61	15583	Pin	N/A	10322	Grease Fitting 1/4"-28 Thd