

ITEM NO.	PART NUMBER	QTY REQD.	NOMENCLATURE OR DESCRIPTION
1	10002	2	HEX BOLT (1/4" X 1")
2	10029	4	HEX BOLT (3/8" X 1-1/4")
3	10091	4	HEX BOLT (5/8" X 1-1/2")
4	10165	4	HEX NUT (5/8" PLATED)
5	10175	8	LOCK NUT 3/8" REVERSE LN
6	10185	4	LOCK WASHER (5/8" PLATED)
7	10200	2	FLAT WASHER (1/4" PLATED)
8	10202	8	FLAT WASHER, 3/8 USS PLATED
9	10419	2	HITCH PIN
10	10335	.25G	PAINT, RED, FAST DRY
11	10339	2	POP RIVET 1/8" X 3/8"
12	10346	2	LYNCH PIN, HITCH SNAP PIN
13	10765	1	TANK - 300 GAL
14	10773	1	AGITATOR
15	10797	36"	3/4" ID HOSE CLEAR, 40 PSI
16	10804	1	LEVEL INDICATOR FLOAT
17	10031	2	HEX BOLT (3/8" X 1")
18	11016	1	DECAL, SPRAYER SAFETY LIST
19	11727	1	SERIAL NUMBER PLATE
20	11850	1	WEBSITE DECAL (NOT SHOWN)
21	12350	1	STRAINER 1"X50M
22	10827	1	1" PP BALL VALVE
23	11131	1	HARDEE LOGO (5" X 16") NOT SHOWN
24	10538	2	SLEEVE
25	13355	3	3/4" MNPT X 3/4" HB ELBOW (POLY)
26	15059	2	1"PP NIPPLE
27	13859	1	BUSHING 1" X 3/4"
28	13531	2	CLAMP

DWG. NO.			REV.	
30099			A	
REV	CHANGE	BY	DATE	ECN
IR	INITIAL RELEASE	C.K.N.	1/29/14	---
A	13353 ADDED TO DRAWING	K.H.N.	4/23/14	1560

29	13510	1	1" PP STREET ELBOW
30	13847	1	1-1/4" X 1" BUSHING
31	15477	132	2" WEBBING STRAP (5000lb/in)
32	15478	4	NYLON TANK STRAP END
33	15852	2	RED REFLECTOR (NOT SHOWN)
34	15854	1	MANUAL HOLDER
35	15860	2	U-NUT 1/4"-20
36	15911	4	HEX BOLT, 3/8 X 2-1/2
37	30067	2	UPRIGHT MEMBER
38	30271	1	WELDMENT, 200 & 300 FRAME
39	30291	2	SADDLE WELDMENT 38"
40	30436	1	300 GAL TANK INSERT
41	30455	1	WELDMENT SPRAYER CONTROL STAND
42	15333	1	REPLACEMENT LID/CAP 8"
43	13353	1	ELBOW 1/2" HB x 3/4" NPT-POLY

All Dimensions in Inches Unless Otherwise Specified
Dimensions in [] are in Millimeters

Tolerances Unless Otherwise Specified
Fractional Dimensions ±1/16" Angular Dimensions ±1"
Decimal Dim. to Limits Shown All holes to be ⁺⁰/_{-1/32}

DRAWN BY	C.K.N.	1/29/14	HARDEE BY EVH MFG. CO. LORIS S.C.	
CHECKED BY				
MATERIAL	R.M.N.		APPLICATION L-300	OLD PART # ----
MANUFACTURED BY HARDEE BY EVH			DESCRIPTION L-300 SPRAYER FRAME AND TANK COMPLETE	
DO NOT SCALE	A	DWG. NO.	SHEET 1 OF 3 30099	

DWG. NO.

30099

REV.

A

REV	CHANGE	BY	DATE	ECN
IR	INITIAL RELEASE	C.K.N.	1/29/14	---
A	13353 ADDED TO DRAWING	K.H.N.	4/23/14	1560

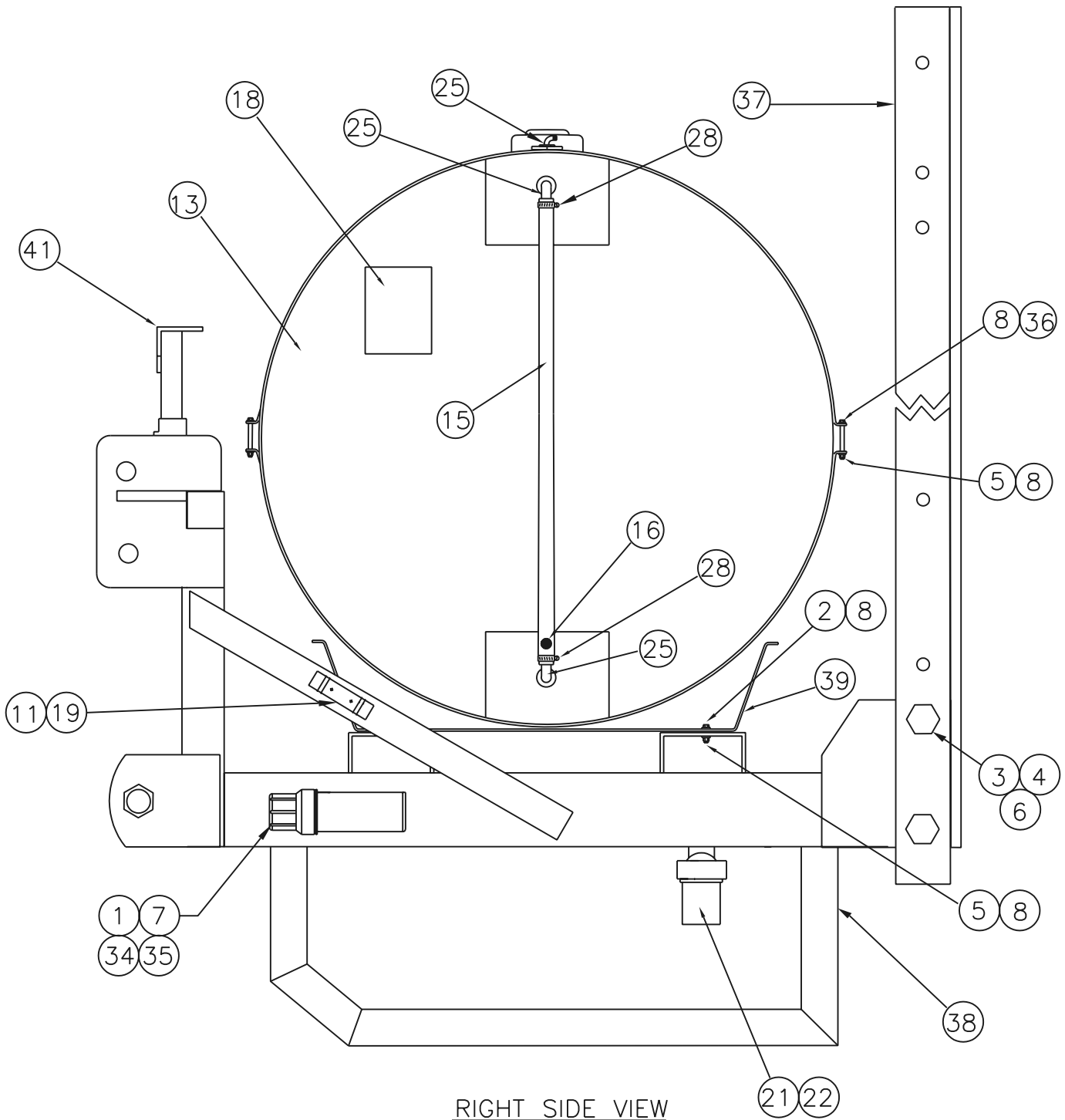

RIGHT SIDE VIEW

DRAWN BY	C.K.N.	1/29/14	HARDEE BY EVH MFG. CO. LORIS S.C.	
CHECKED BY				
MATERIAL	R.M.N.		APPLICATION	OLD PART #
MANUFACTURED BY HARDEE BY EVH			L-300	----
			DESCRIPTION	L-300 SPRAYER FRAME AND TANK COMPLETE
DO NOT SCALE	A	DWG. NO.	SHEET 2 OF 3	
	DWG SIZE	30099		

All Dimensions in Inches Unless Otherwise Specified
 Dimensions in [] are in Millimeters

Tolerances Unless Otherwise Specified
 Fractional Dimensions $\pm 1/16"$
 Decimal Dim. to Limits Shown

Angular Dimensions $\pm 1'$
 All holes to be $+0/-1/32$

DWG. NO.

30099

REV.

A

REV	CHANGE	BY	DATE	ECN
IR	INITIAL RELEASE	C.K.N.	1/29/14	---
A	13353 ADDED TO DRAWING	K.H.N.	4/23/14	1560

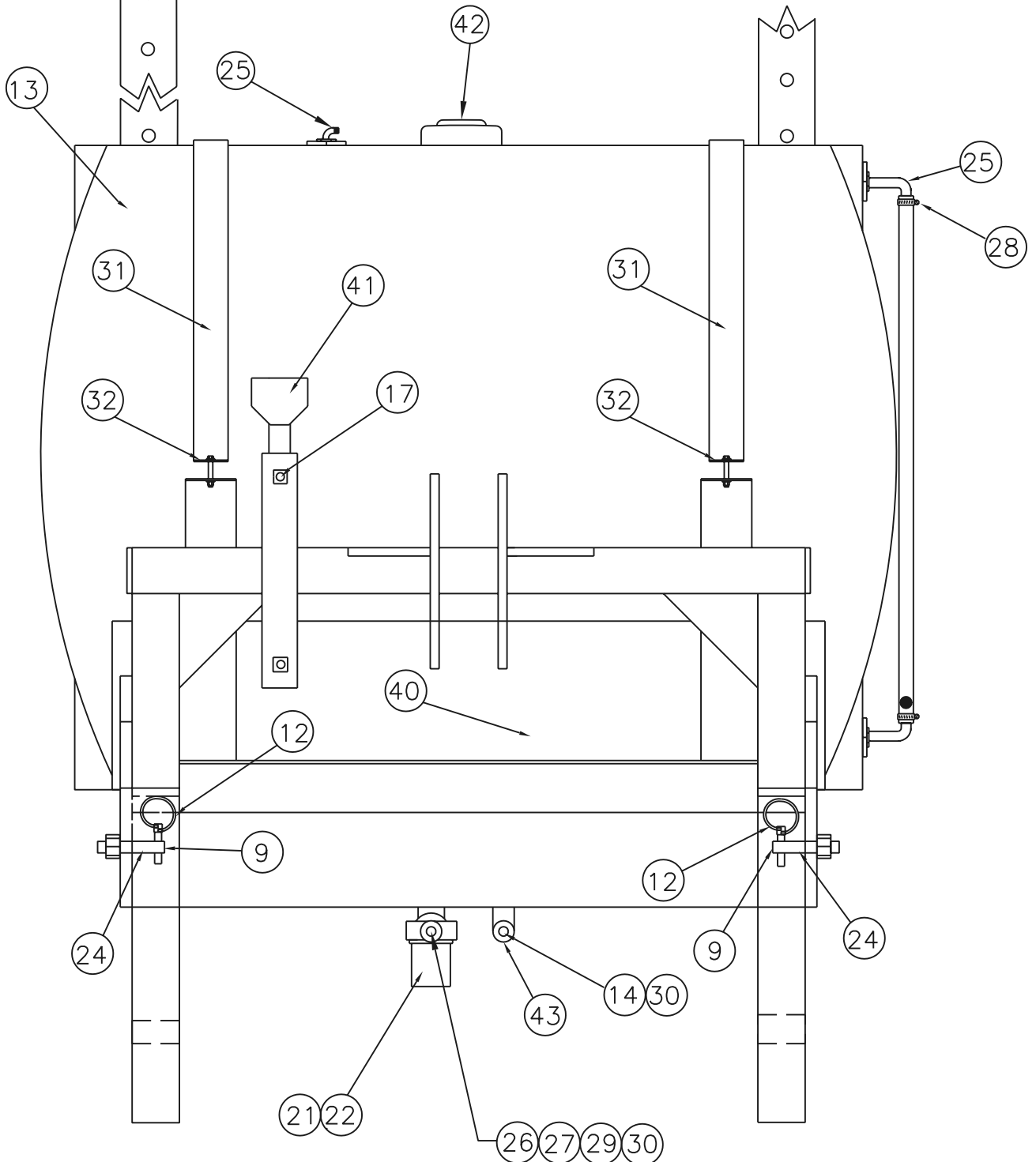

FRONT VIEW

DRAWN BY	C.K.N.	1/29/14
CHECKED BY		
MATERIAL	R.M.N.	
MANUFACTURED BY HARDEE BY EVH		

**HARDEE BY
EVH MFG. CO.
LORIS S.C.**

APPLICATION	OLD PART #
L-300	---
DESCRIPTION L-300 SPRAYER FRAME AND TANK COMPLETE	
DO NOT SCALE	DWG. NO. 30099
A	SHEET 3 OF 3

All Dimensions in Inches Unless Otherwise Specified
Dimensions in [] are in Millimeters

Tolerances Unless Otherwise Specified
Fractional Dimensions $\pm 1/16"$ Angular Dimensions $\pm 1'$
Decimal Dim. to Limits Shown All holes to be $\begin{matrix} +0 \\ -1/32 \end{matrix}$