

ABH-96 Rear Blade Complete

DWG. NO.	40034		REV.	
REV	CHANGE	BY	DATE	ECN
G	Weldment updated (Complete machine created in Creo 2.0)	T.B.B.	8/25/15	1626
H	Replace stabilizer w/Ratchet Jack	C.K.N.	6/15/16	1658
I	SHOWED CAT. 1 & 2 QUICK HITCH.	M.J.Z.	10/20/21	1799

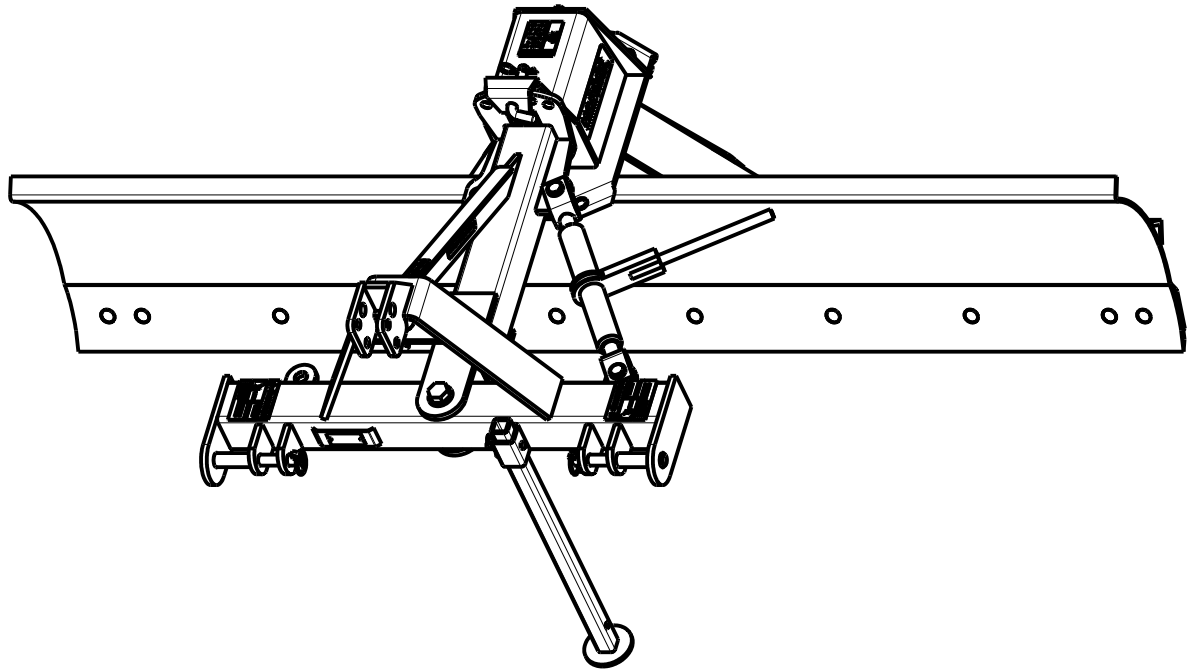

Item	Part Number	Qty.	Description
1	10072	4	HEX BOLT, 1/2 x 1 1/2 Gr.5 PLATED
2	10136	1	HEX BOLT 1 x 6 1/2 Gr.5 PLATED
3	10166	10	LOCKNUT, 5/8"-11 PLATED
4	10171	1	HEX NUT, 1"-14 PLATED
5	10184	4	LOCKWASHER, 1/2" PLATED
6	10207	4	FLATWASHER, 1" PLATED
7	10252	1	COTTER PIN, 3/16" X 2" PLATED
8	10262	10	PLOW BOLT, 5/8" X 1-1/2 Gr.5 PLATED
9	10335	1	HARDEE RED PAINT - (Not Shown)
10	10339	2	POP RIVET
11	10343	1	RATCHET JACK
12	10346	2	3 Pt. Snap Pin (Lynch Pin)
13	10390	1	CLIP PIN (1/8 x 2)
14	10391	6	Clip Pin (Hairpin) 3/16 X 3-1/4"
15	10393	1	UNIVERSAL CLIP PIN
16	10434	1	96 Cutting Edge
17	10445	1	3/4 Dia. Bent Hitch Pin
18	10446	4	CLEVIS PIN (1 X 2 5/8)
19	10447	1	CLEVIS PIN (1 X 5)
20	10464	2	CATEGORY I & II HITCH PIN
21	11032	2	DECAL, SMALL HARDEE LOGO
22	11131	1	DECAL, HARDEE BY EVH MFG (5 X 16)
23	11413	1	Castle Nut, 1" Gr.5 Plated Fine Thrd.
24	11610	1	ABH-96 I.D. DECAL (LARGE)
25	11636	1	DECAL, Landscape & Disc Harrow Kit
26	11636-1	1	WARNING DECAL (KIT 11636)
27	11636-2	1	WARNING DECAL (KIT 15845)
28	11636-3	3	WARNING DECAL (KIT 11636)
29	11636-4	2	WARNING DECAL (KIT 11636)
30	11636-5	2	DANGER DECAL (KIT 11636)
31	11636-6	1	WARNING DECAL (KIT 11636)
32	11727	1	SERIAL NUMBER PLATE
33	11850	1	DECAL, WEB SITE
34	40035	1	Rear Blade Front Frame Weldment
35	40036	1	Rear Blade Center Frame Weldment
36	40037	1	Rear Blade Carriage Housing Weldment
37	40058	1	Outer Pivot Cap
38	40087	1	ABH96 Rear Blade Weldment
39	40227	1	Pivot Bolt Weldment
40	40308	1	ABH Stand Weldment

MODELED BY	J. CREEL	N/A	HARDEE BY EVH MFG. CO. LORIS S.C.	
DRAWN BY	T.B.B.	8/25/15		
DESCRIPTION			SHEET 1 of 3	
ABH-96 REAR SCRAPER				
DO NOT SCALE	A	DWG. NO.	40034	
MATERIAL		R.M.N. N/A		
Manufactured By: EVH Mfg. Co., LLC				

All Dimensions in Inches Unless Otherwise Specified
 Dimensions in [] are in Millimeters
 Tolerance Unless Otherwise Specified
 Fractional Dimensions: ± 1/16"
 Decimal Dim. to Limits Shown
 Angular Dimensions: ± 1°
 All Holes to be +0 -1/32"

Item	Part Number	Qty.	Description
1	10072	4	HEX BOLT, 1/2 x 1 1/2 Gr.5 PLATED
2	10136	1	HEX BOLT 1 x 6 1/2 Gr.5 PLATED
3	10166	10	LOCKNUT, 5/8"-11 PLATED
4	10171	1	HEX NUT, 1"-14 PLATED
5	10184	4	LOCKWASHER, 1/2" PLATED
6	10207	4	FLATWASHER, 1" PLATED
7	10252	1	COTTER PIN, 3/16" X 2" PLATED
8	10262	10	PLOW BOLT, 5/8" X 1-1/2 Gr.5 PLATED
9	10335	1	HARDEE RED PAINT - (Not Shown)
10	10339	2	POP RIVET
11	10343	1	RATCHET JACK
12	10346	2	3 Pt. Snap Pin (Lynch Pin)
13	10390	1	CLIP PIN (1/8 x 2)
14	10391	6	Clip Pin (Hairpin) 3/16 X 3-1/4"
15	10393	1	UNIVERSAL CLIP PIN
16	10434	1	96 Cutting Edge
17	10445	1	3/4 Dia. Bent Hitch Pin
18	10446	4	CLEVIS PIN (1 X 2 5/8)
19	10447	1	CLEVIS PIN (1 X 5)
20	10464	2	CATEGORY I & II HITCH PIN
21	11032	2	DECAL, SMALL HARDEE LOGO
22	11131	1	DECAL, HARDEE BY EVH MFG (5 X 16)
23	11413	1	Castle Nut, 1" Gr.5 Plated Fine Thrd.
24	11610	1	ABH-96 I.D. DECAL (LARGE)
25	11636	1	DECAL, Landscape & Disc Harrow Kit
26	11636-1	1	WARNING DECAL (KIT 11636)
27	11636-2	1	WARNING DECAL (KIT 15845)
28	11636-3	3	WARNING DECAL (KIT 11636)
29	11636-4	2	WARNING DECAL (KIT 11636)
30	11636-5	2	DANGER DECAL (KIT 11636)
31	11636-6	1	WARNING DECAL (KIT 11636)
32	11727	1	SERIAL NUMBER PLATE
33	11850	1	DECAL, WEB SITE
34	40035	1	Rear Blade Front Frame Weldment
35	40036	1	Rear Blade Center Frame Weldment
36	40037	1	Rear Blade Carriage Housing Weldment
37	40058	1	Outer Pivot Cap
38	40087	1	ABH96 Rear Blade Weldment
39	40227	1	Pivot Bolt Weldment
40	40308	1	ABH Stand Weldment

DWG. NO.	40034			REV.	
REV	CHANGE	BY	DATE	ECN	
G	Weldment updated (Complete machine created in Creo 2.0)	T.B.B.	8/25/15	1626	
H	Replace stabilizer w/Ratchet Jack	C.K.N.	6/15/16	1658	
I	SHOWED CAT. 1 & 2 QUICK HITCH.	M.J.Z.	10/20/21	1799	

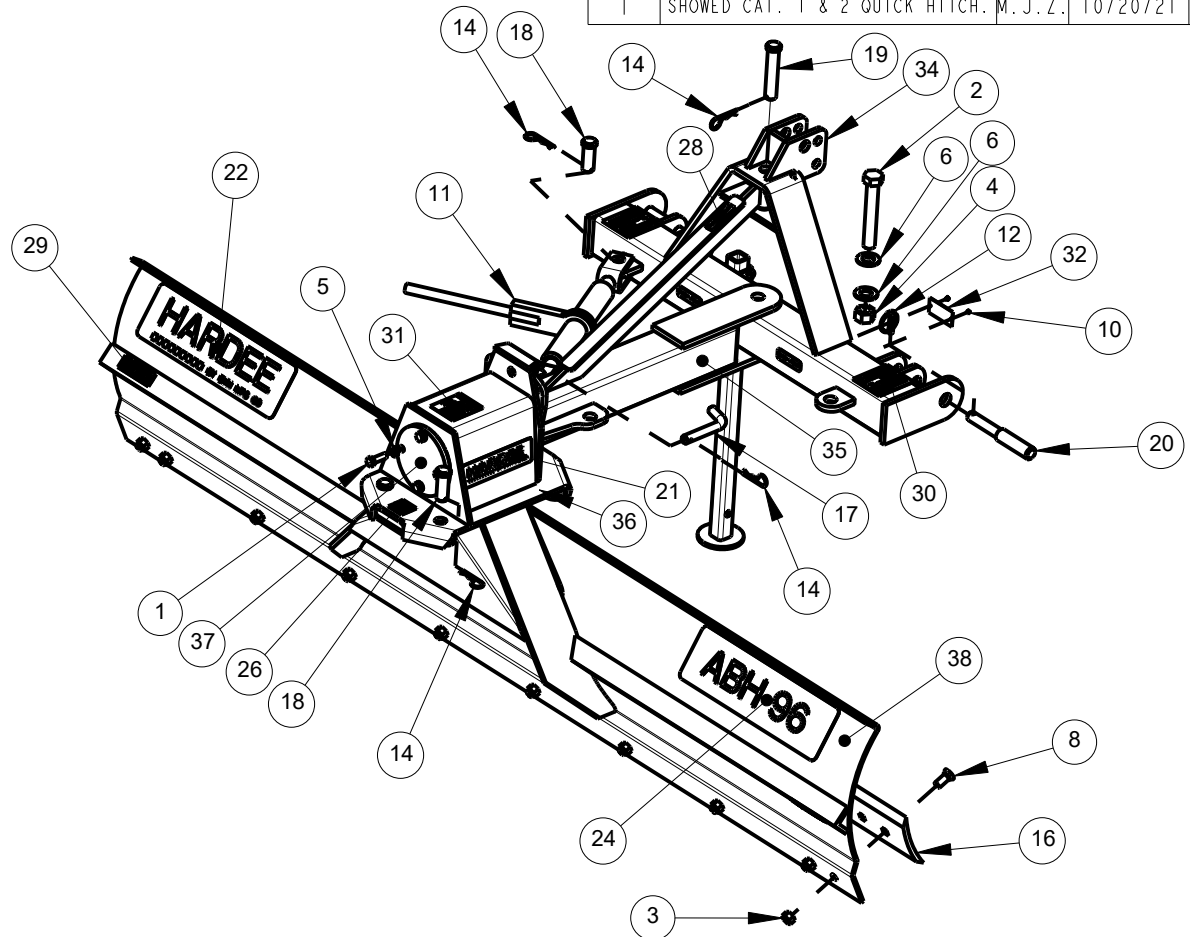

MODELED BY	J. CREEL	N/A	HARDEE BY EVH MFG. CO. LORIS S.C.		
DRAWN BY	T.B.B.	8/25/15			
MATERIAL			R.M.N.	DESCRIPTION	SHEET 2 of 3
			N/A	ABH-96 REAR SCRAPER	
Manufactured By: EVH Mfg. Co., LLC			DO NOT SCALE	A DWG. NO.	40034

All Dimensions in Inches Unless Otherwise Specified
Dimensions in [] are in Millimeters
Tolerance Unless Otherwise Specified
Fractional Dimensions: ± 1/16"
Decimal Dim. to Limits Shown
Angular Dimensions: ± 1°
All Holes to be +0 -1/32"

Item	Part Number	Qty.	Description
1	10072	4	HEX BOLT, 1/2 x 1 1/2 Gr.5 PLATED
2	10136	1	HEX BOLT 1 x 6 1/2 Gr.5 PLATED
3	10166	10	LOCKNUT, 5/8"-11 PLATED
4	10171	1	HEX NUT, 1"-14 PLATED
5	10184	4	LOCKWASHER, 1/2" PLATED
6	10207	4	FLATWASHER, 1" PLATED
7	10252	1	COTTER PIN, 3/16" X 2" PLATED
8	10262	10	PLOW BOLT, 5/8" X 1-1/2 Gr.5 PLATED
9	10335	1	HARDEE RED PAINT - (Not Shown)
10	10339	2	POP RIVET
11	10343	1	RATCHET JACK
12	10346	2	3 Pt. Snap Pin (Lynch Pin)
13	10390	1	CLIP PIN (1/8 x 2)
14	10391	6	Clip Pin (Hairpin) 3/16 X 3-1/4"
15	10393	1	UNIVERSAL CLIP PIN
16	10434	1	96 Cutting Edge
17	10445	1	3/4 Dia. Bent Hitch Pin
18	10446	4	CLEVIS PIN (1 X 2 5/8)
19	10447	1	CLEVIS PIN (1 X 5)
20	10464	2	CATEGORY I & II HITCH PIN
21	11032	2	DECAL, SMALL HARDEE LOGO
22	11131	1	DECAL, HARDEE BY EVH MFG (5 X 16)
23	11413	1	Castle Nut, 1" Gr.5 Plated Fine Thrd.
24	11610	1	ABH-96 I.D. DECAL (LARGE)
25	11636	1	DECAL, Landscape & Disc Harrow Kit
26	11636-1	1	WARNING DECAL (KIT 11636)
27	11636-2	1	WARNING DECAL (KIT 15845)
28	11636-3	3	WARNING DECAL (KIT 11636)
29	11636-4	2	WARNING DECAL (KIT 11636)
30	11636-5	2	DANGER DECAL (KIT 11636)
31	11636-6	1	WARNING DECAL (KIT 11636)
32	11727	1	SERIAL NUMBER PLATE
33	11850	1	DECAL, WEB SITE
34	40035	1	Rear Blade Front Frame Weldment
35	40036	1	Rear Blade Center Frame Weldment
36	40037	1	Rear Blade Carriage Housing Weldment
37	40058	1	Outer Pivot Cap
38	40087	1	ABH96 Rear Blade Weldment
39	40227	1	Pivot Bolt Weldment
40	40308	1	ABH Stand Weldment

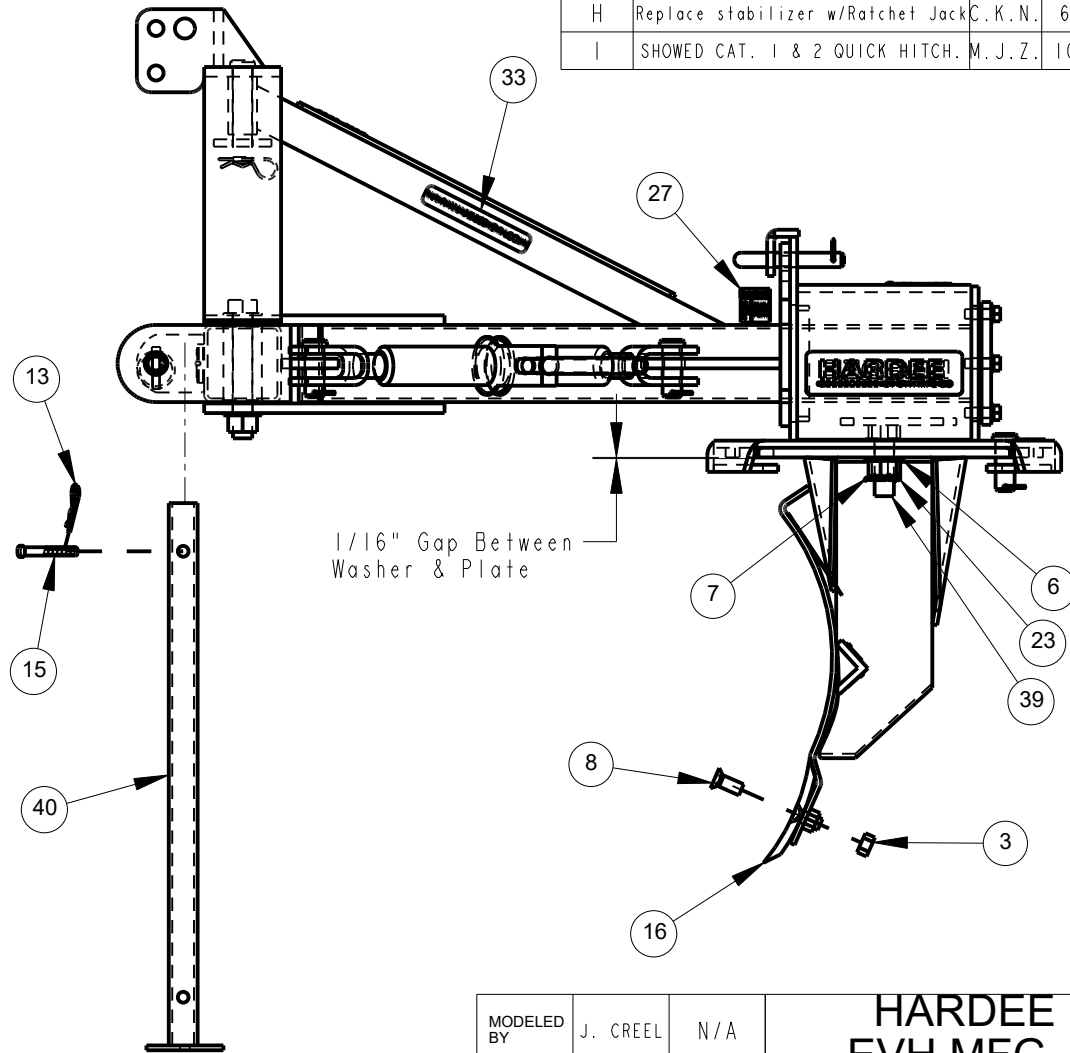

DWG. NO.	40034			REV.	
REV	CHANGE	BY	DATE	ECN	
G	Weldment updated (Complete machine created in Creo 2.0)	T.B.B.	8/25/15	1626	
H	Replace stabilizer w/Ratchet Jack	C.K.N.	6/15/16	1658	
I	SHOWED CAT. 1 & 2 QUICK HITCH.	M.J.Z.	10/20/21	1799	

MODELED BY	J. CREEL	N/A	HARDEE BY EVH MFG. CO. LORIS S.C.	
DRAWN BY	T.B.B.	8/25/15		
DESCRIPTION			SHEET 3 of 3	
MATERIAL			ABH-96 REAR SCRAPER	
R.M.N. N/A			DO NOT SCALE	A DWG. NO.
Manufactured By: EVH Mfg. Co., LLC			40034	

All Dimensions in Inches Unless Otherwise Specified	
Dimensions in [] are in Millimeters	
Tolerance Unless Otherwise Specified	
Fractional Dimensions: ± 1/16"	Angular Dimensions: ± 1°
Decimal Dim. to Limits Shown	All Holes to be +0 -1/32"